

**HYDRAULIC EXCAVATOR**

# TB370

**takeuchi**<sup>TM</sup>  
*From World First to World Leader*

PROUDLY DISTRIBUTED BY



**MATERIAL HANDLING**

**1800 425 438**

[toyotatakeuchi.com.au](http://toyotatakeuchi.com.au)



**Operating Weight: 7,900 kg**

# Product Features & Specifications

## ENGINE

- EU Stage V/ EPA Tier 4 Compliant
- Turbocharged
- DOC + DPF Exhaust After Treatment
- Automatic Fuel Bleed System
- Double Element Air Cleaner
- Automatic Deceleration
- Working Modes; Standard and Eco
- Engine Preheat Starting Aid
- High Capacity Radiator and Hydraulic Oil Cooler
- High Capacity Fuel Filters
- Engine Safety Start System on Left Console
- Engine Auto Stop
- Fuel Supply Pump with Hose Reel

## WORKING EQUIPMENT

- Independent Mono Boom Swing
- 2-Piece Variable Angle Boom (Optional)
- Cushioned Boom, Arm and Swing Cylinders
- Boom Swing Stopper (Optional)
- 1,700 mm Arm
- 1,900 mm Arm
- Boom Holding Valve w/ Lift Alarm
- Arm Holding Valve (Optional)
- Adjust Holding Valve (Optional)
- Pattern Change Valve (ISO or G) (Optional)
- Bucket Operation Angle Selection Device (Optional)
- Lifting Point of Bucket Linkage (Optional)

## TAKEUCHI FLEET MANAGEMENT

- Minimize Downtime
- Remote Diagnostics
- Utilization Tracking
- Proactive Maintenance
- Control Costs

## OPERATOR'S STATION

- ROPS/TOPS/OPG (TOP Guard, Level 1)
- Deluxe High Back Suspension Seat with Head Rest
- Air Suspension Seat with Heat (Optional)
- 12V Power Outlet
- 2" Retractable Seat Belt
- Rain Guard (Optional)
- OPG Level II Roof Guard Kit (Optional)
- OPG Level II Front Guard (Optional)
- Cab with Automatic Climate Control System, Windshield Wiper and Washer, Skylight with Sunshade, DAB Radio with Bluetooth

## UNDERCARRIAGE AND FRAME

- Triple Flanged Track Rollers
- 2-Speed Travel with Automatic Shift
- High Torque Planetary Final Drive
- Heavy Duty Dozer Blade with Float (Optional)
- Large Wrap Around Counterweight
- Extra Heavy Counterweight (Optional)
- 400 mm Rubber Crawlers
- 400 mm Steel Crawlers (Optional)
- 400 mm Segmented Rubber Crawlers (Optional)
- Rubber Pads for 400 mm Steel Crawlers (Optional)
- Power Angle Blade with Float and Bolt-On Cutting Edge (Optional)
- Check Valve, Dozer Blade (Optional)

## HYDRAULIC

- Closed Center, Load Sensing Hydraulics
- Hydraulic Joystick Controls
- Proportional Controls for Service Port 1
- Dentent for Service Port 1
- Proportional Controls for Service Port 2
- Service Port 3 for Quick Hitch (Optional)
- Proportional Controls for Service Port 4 (Optional)
- Simultaneous Operation for Service Port 2 and Service Port 4 (Optional)
- Auxiliary Hydraulic Circuit Plumbed to Arm
- Hydraulic Tank w/ Fluid Sight Gauge
- Adjustable Auxiliary Flow for Service Port 1, 2, and 4
- Pressure Adjustment for Service Port 1, 2, and 4 (Optional)
- Auto Pressure Release (Optional)
- Hydraulic Valve (1-way/2-way)
- Pilot Accumulator
- Air Breather, Hydraulic Tank
- Auto Tank (Optional)

## ELECTRICAL

- 8" Color Touch Screen Display
- Multi-Switch Control Panel
- 12 Volt System with 90 amp Alternator
- LED Light Package 1; Right Cover, Boom, Front Cab (Optional)
- LED Light Package 2; Right Cover, Boom, Front Cab & Rear Cab (Optional)
- Travel Alarm (Optional)
- Beacon Socket and Lamp Switch
- TFM (Takeuchi Fleet Management;)\*
- TSS (Takeuchi Security System; Immobilizer)\* (Optional)
- Rear View Monitor (Optional)
- 270° View Monitor (Optional)



2-Piece Boom



Auxiliary Hydraulic Lines



Hydraulic Joystick Controls



Large Floor with Foot Rest

\*Functions may not be available in all countries, so please consult your Takeuchi dealer for details.



8" Color Touch Screen Display



Intuitive Jog Dial & Multi-Switch Panel



270° View Monitor (Optional)

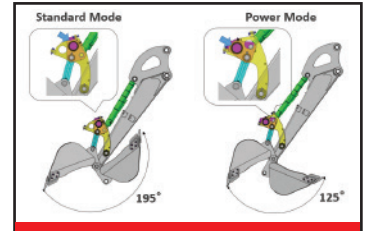

Bucket Angle Selection Device

The TB370 comes standard with a mono boom and optional 2-piece boom, tilt-up cabin, an 8" color touch screen display plus jog dial controls, and a 42.4 kW engine that delivers superior performance and attachment handling. As the first model of Takeuchi's new generation lineup, the TB370 has state-of-the-art technology and a completely redesigned automotive styled interior with intuitive user's operation. The most machine functions and settings, including air conditioning, radio, rear/270° view monitor and engine speed can be quickly accessed through 8" touch screen display and jog dial controls for maximum convenience.

Best in class operation for quiet ride and excellent performance. TB370 has very low external noise levels and are specially well-suited for work in urban areas while offering unparalleled engine power and hydraulic performance. Also it offers superior working range and the combination of excellent power and superior working range delivers extra productivity.

Additional features include large around counterweight, exceptional serviceability, fuel supply pump with hose reel and bucket operation angle selection device in which the operator can switch the bucket angle between 125° and 195° from the operator's seat without getting on/off the machine.



Completely Redesigned Automotive Styled Interior with Intuitive User's Operation

# TOUGH, POWERFUL, RELIABLE

## OPERATING PERFORMANCE

Mono Boom 2-Piece Boom

Operating Weight		
- Rubber Crawlers	6,710 kg	7,065 kg
Bucket Capacity (Heaped)	0.18 m <sup>3</sup>	
Slew Speed	8.8 min-1	
Travel Speed		
1st	2.5 km/h	
2nd	4.7 km/h	
Gradeability	30°	
Ground Pressure - Mono	37.0 kPa	
Ground Pressure - 2-Piece	39.0 kPa	
Maximum Bucket Breakout Force	48.4 kN	
Maximum Arm Digging Force (1,700 mm Arm)	31.7 kN	
Maximum Arm Digging Force (1,900 mm Arm)	29.4 kN	
Traction Force	73.3 kN	
Boom Swing Angle (Left/Right)	79° / 51°	

## ENGINE

Model	Kubota V2607-CR-TE5B	
Rated Output (ISO 14396)	42.4 kW / 2,000 min-1	
Maximum Torque (ISO 14396)	213.4 Nm / 1,300 min-1	
Displacement	2,615 ml	
Alternator	12 V - 1.08 kW	
Battery (IEC 60095-1)	12 V - 90 A * h	

## FLUID CAPACITY

Engine Lubrication	9.0 L
Cooling System	11.0 L
Fuel Tank Capacity	110.0 L
Hydraulic Reservoir Capacity	65.5 L
Hydraulic System Capacity	139.0 L



Easy Service Access with Wide-Opening Hoods

## HYDRAULIC SYSTEM

Mono Boom 2-Piece Boom

P1	Variable Displacement Pump	
Flow Rate	160.0 L/min	
Relief Pressure	24.5 MPa	
P2	Gear Pump	
Flow Rate	46.6 L/min	
Relief Pressure	24.0 MPa	
Service Port 1		
Flow Rate	120.0 L/min	
Hydraulic Pressure	20.6 MPa	
Service Port 2		
Flow Rate	46.6 L/min	
Hydraulic Pressure	20.6 MPa	
Service Port 3		
Hydraulic Pressure	24.5 MPa	
Service Port 4		
Flow Rate	46.6 L/min	
Hydraulic Pressure	20.6 MPa	

## SAFETY and HEALTH

### Vibration Levels

Hand / Arm	≤ 2.5 m/s <sup>2</sup>
Body	≤ 0.5 m/s <sup>2</sup>

### Noise Level

Sound Power Level	L <sub>WA</sub> 95 dB
-------------------	-----------------------



Tilt-Up Cabin Delivering Excellent Serviceability

# Mono Boom

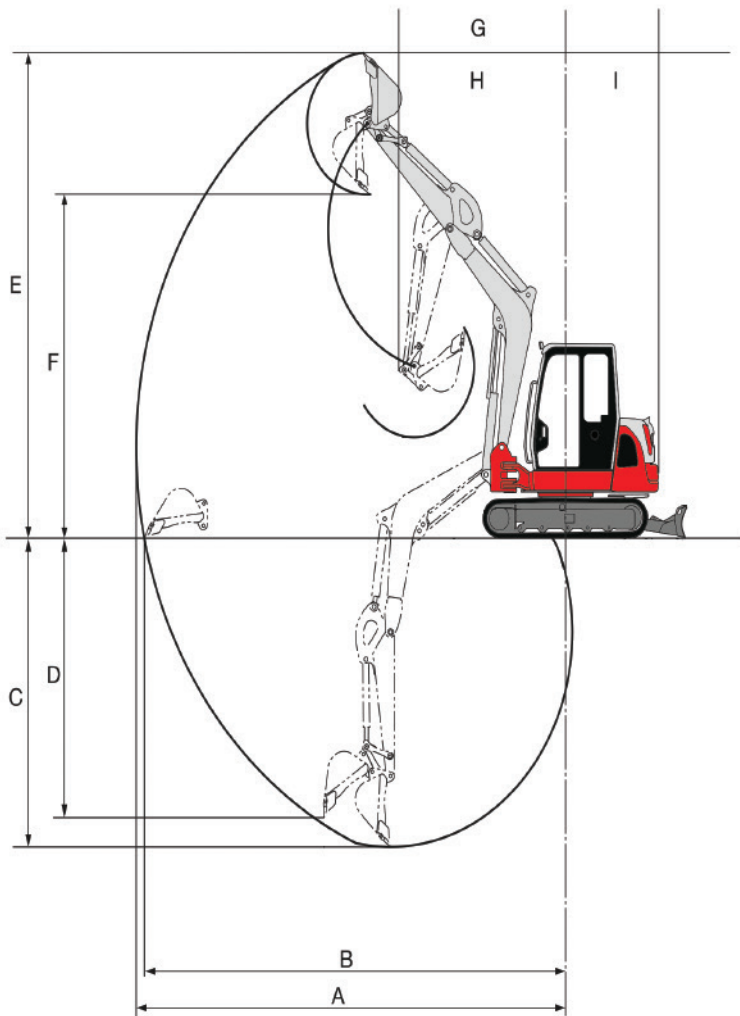

# 2-Piece Boom

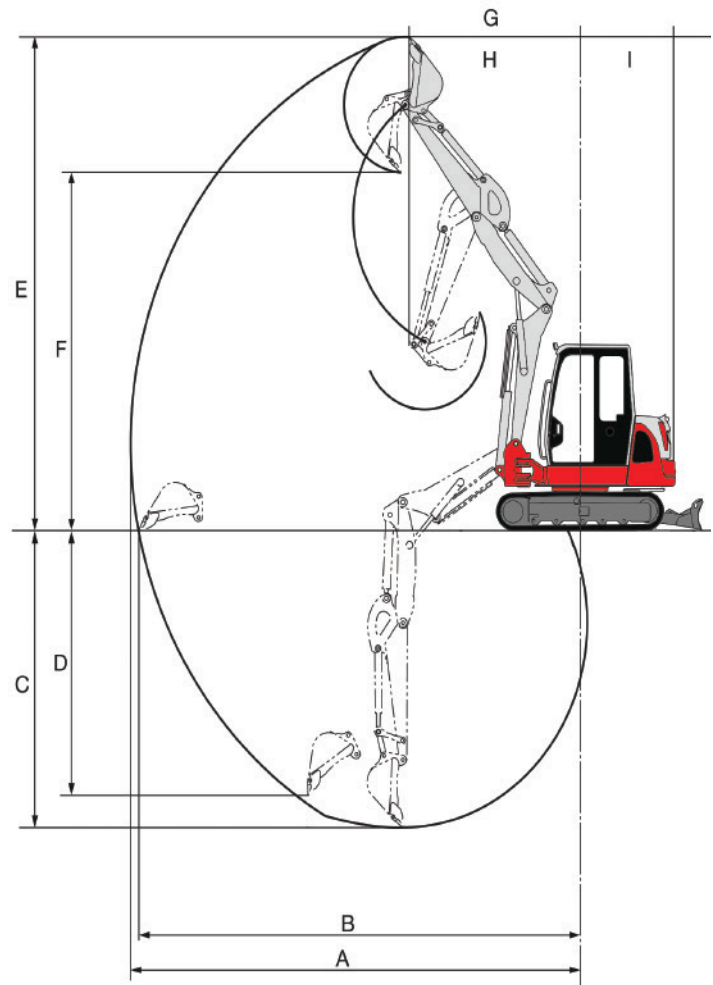

MACHINE DIMENSIONS	Mono Boom 1,700 mm ARM	Mono Boom 1,900 mm ARM	2-Piece Boom 1,900 mm ARM
A Maximum Reach	6,500 mm	6,690 mm	6,905 mm
B Maximum Reach at Ground Level	6,365 mm	6,565 mm	6,785 mm
C Maximum Digging Depth	3,885 mm	4,085 mm	4,110 mm
D Maximum Vertical Digging Depth	3,605 mm	3,815 mm	3,840 mm
E Maximum Height of Cutting Edge	6,270 mm	6,420 mm	6,825 mm
F Maximum Dumping Height	4,400 mm	4,545 mm	4,955 mm
G Front Swing Radius	2,525 mm	2,585 mm	2,630 mm
H Front Swing Radius with Boom Offset	1,990 mm	2,040 mm	2,080 mm
I Slew Radius	1,455 mm	1,455 mm	-
I' Slew Radius with Extra Weight	1,480 mm	1,480 mm	1,480 mm

© 2020 Takeuchi MFG. Co., Ltd. All Rights Reserved. In accordance with our established policy of continued improvement, specifications and features are subject to change without notice. Pictures may show options other than standard equipment.

**TAKEUCHI**  
From World First to World Leader

## Mono Boom

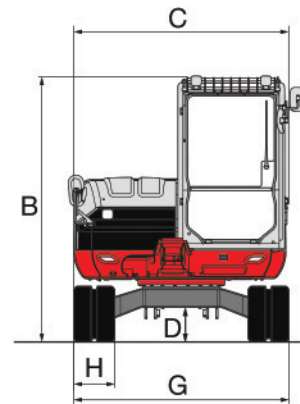
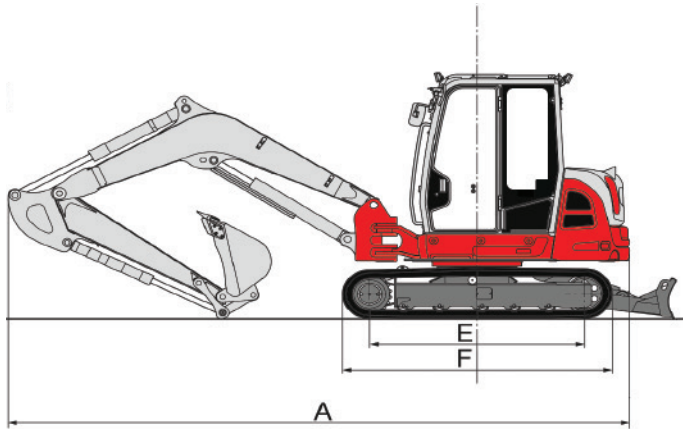

## 2-Piece Boom

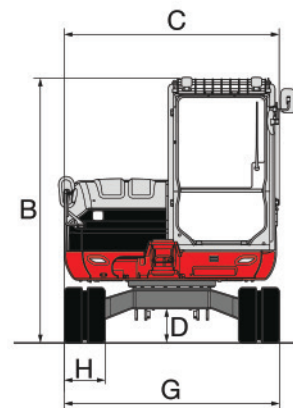
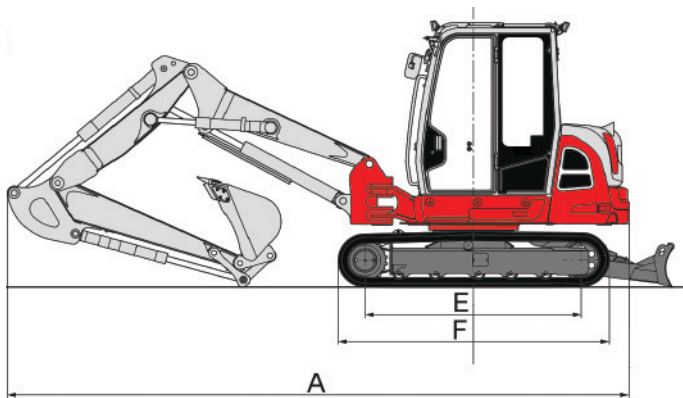

MACHINE DIMENSIONS	Mono Boom 1,700 mm ARM	Mono Boom 1,900 mm ARM	2-Piece Boom 1,900 mm ARM
A Overall Length	5,930 mm	5,925 mm	—
A' Overall Length with Extra Weight	5,955 mm	5,950 mm	5,900 mm
B Overall Height	2,540 mm	2,540 mm	2,540 mm
B' Overall Height with Roof Guard	2,580 mm	2,580 mm	2,580 mm
C Upper Structure Overall Width	2,095 mm	2,095 mm	2,095 mm
D Ground Clearance	335 mm	335 mm	335 mm
E Crawler Base	2,050 mm	2,050 mm	2,050 mm
F Crawler Overall Length	2,575 mm	2,575 mm	2,575 mm
G Crawler Overall Width	2,100 mm	2,100 mm	2,100 mm
H Crawler Shoe Width	400 mm	400 mm	400 mm

PROUDLY DISTRIBUTED BY



MATERIAL HANDLING

**1800 425 438**

[toyotatakeuchi.com.au](http://toyotatakeuchi.com.au)